

# 12K 2-POST LIFT

## SERVICE BAY SPECIFICATIONS

- HEIGHT:** 14'15' MINIMUM
- WIDTH:** 14' RECOMMENDED
- DEPTH:** 24' RECOMMENDED
- POWER:** 208-230VAC, 1PH, 30A

**CONCRETE:**  
4" thick, reinforced, free from cracks/  
seams, 3500+ psi & cured 28+ days



## SPECIFICATIONS

| 12K 2-Post                                | EELR537B  | EELR537B w/2 Ft. Ext. Kit   |
|---|---|-----------------------------|
| Lifting Capacity                          | 12,000 lbs.   5,442 kg  |                             |
| Overall Height (Adjustable)               | 13'10"/14'7"   4216-4445mm  | 15'10"/16'7"   4826-5055mm  |
| Ceiling Height Required                   | 167"/176"   4242/4470mm   | 191"/200"   4852/4890mm     |
| Floor to Overhead Switch                  | 13'3½"/14'½"<br>4051/4280mm   | 15'3½"/16'½"<br>4661/4890mm |
| Rise Height (Screw Pads Highest Position) | 77¾"   1975mm   |                             |
| Screw Pad Height                          | 5¼"/6¼"   133/171mm   |                             |
| Overall Width                             | 139¾"   3550mm  |                             |
| Inside of Columns                         | 115"   2921mm   |                             |
| Drive-Thru Clearance                      | 103"   2616mm   |                             |
| Arm Reach (Min.-Max.)                     | 27½"-54½"   699-1386mm  |                             |
| Lifting Capacity                          | 12,000 lbs. (5442 kg)   3,000 lbs. (1361 kg) per arm                            |                             |
| Rise Time                                 | 84 seconds  |                             |
| Motor                                     | 2HP, Single Phase, 60Hz, 208/230V   |                             |
| Hydraulic Pressure at Cap.                | 2600 psi (18MPa)  |                             |
| Bay Requirements                          | Height: 168"/180"   4267/4572mm<br>Width: 168"   4267mm<br>Depth: 288"   7315mm |                             |
| Lift Approximate Weight                   | 2,000 lbs.   907 kg   |                             |
| Lift Shipping Dimensions                  | Length: 132"   353mm<br>Width: 26"   660mm<br>Height: 34"   864mm               |                             |
| Concrete Requirements                     | 4" thick, reinforced, free from cracks/seams, 3500+ psi & cured 28+ days        |                             |

## SERVICE BAY LAYOUT

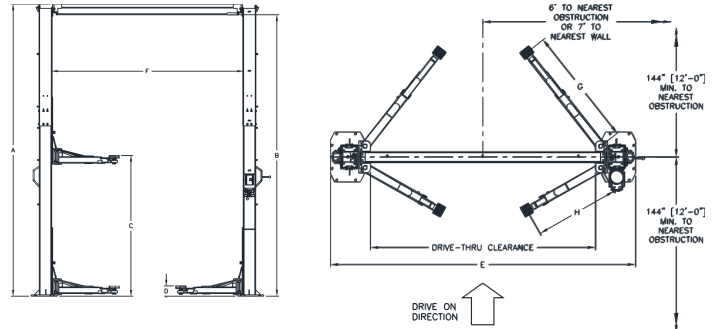

## COMPATIBLE ACCESSORIES

|                           |            |  |
|---------------------------|------------|--|
| Stack Adapter Kit         | 10315      |  |
| Electric Vehicle Footpad  | EVFPK      |  |
| Heavy-Duty Footpad 12K    | B12162S-12 |  |
| Standard Footpad          | B2270      |  |
| GM® Truck Footpad Set     | B2280PR    |  |
| Cab-Off Adapter           | B2290      |  |
| Wheel Service Workstation | B99700     |  |
| Air/Electric Workstation  | B10264A    |  |

## MANUAL PART NUMBERS

Lift

EELR537B-IOM